

# Better Helmets

Ottawa, Canada

A patent licensing opportunity for  
breakthrough helmet technology.

**To build a helmet that targets traumatic brain injuries, instead of just preventing skull fractures & lacerations.**

### **The Need For: *a new sports helmet***

---

No helmet today efficiently protects athletes from all types of impacts.

*Annually, there are ~1.6-3.8 M sports-related concussions just in the United States alone.*

### **What We Bring: *design, tests & patenting***

---

We designed breakthrough helmet technology using specialty foams & structures.

*Canadian & U.S. patents both issued as of Spring 2017.*

### **How You Can Help: *going to market***

---

Filling the void in the market for a helmet company that the public has confidence in.

*Pursuit of licensing agreement(s) or sale of patents.*



## Typical Head Impacts in Sports

No helmet today properly addresses both linear and rotational impacts.

### Linear Impact



Head is impacted with a straight-line force that can cause whiplash and can cause the brain to rebound back and forth within the skull.

### Rotational Impact

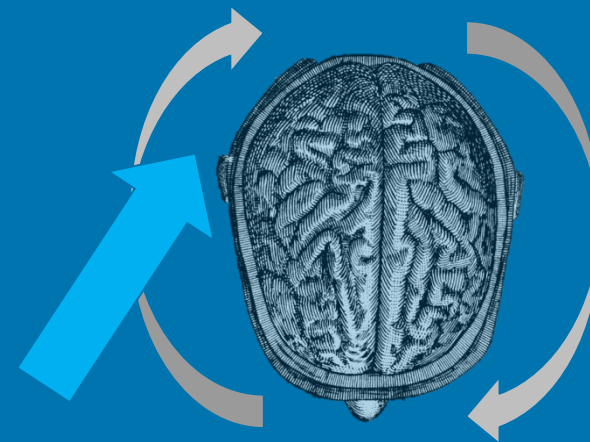

A force glancing off a helmet at an angle can cause rotation of the skull, rubbing on the brain. This can cause shearing of brain tissue and tearing of axons.

# Our Solution

USING SMARTER MATERIALS & STRUCTURES  
TO MAKE A BETTER HELMET

1. *high density memory foam*
2. *closed cell foam liner*
3. *tubular vent structures*

# 1

## Protective, open-cell, constant-resistive force memory foam

Unlike any other helmet on the market today, the constant-resistive force properties of this foam prevent large peak g-forces from being experienced by the head.

This can lower the g-force in an impact by as much as 5.1X when compared to other helmets under similar impact conditions.

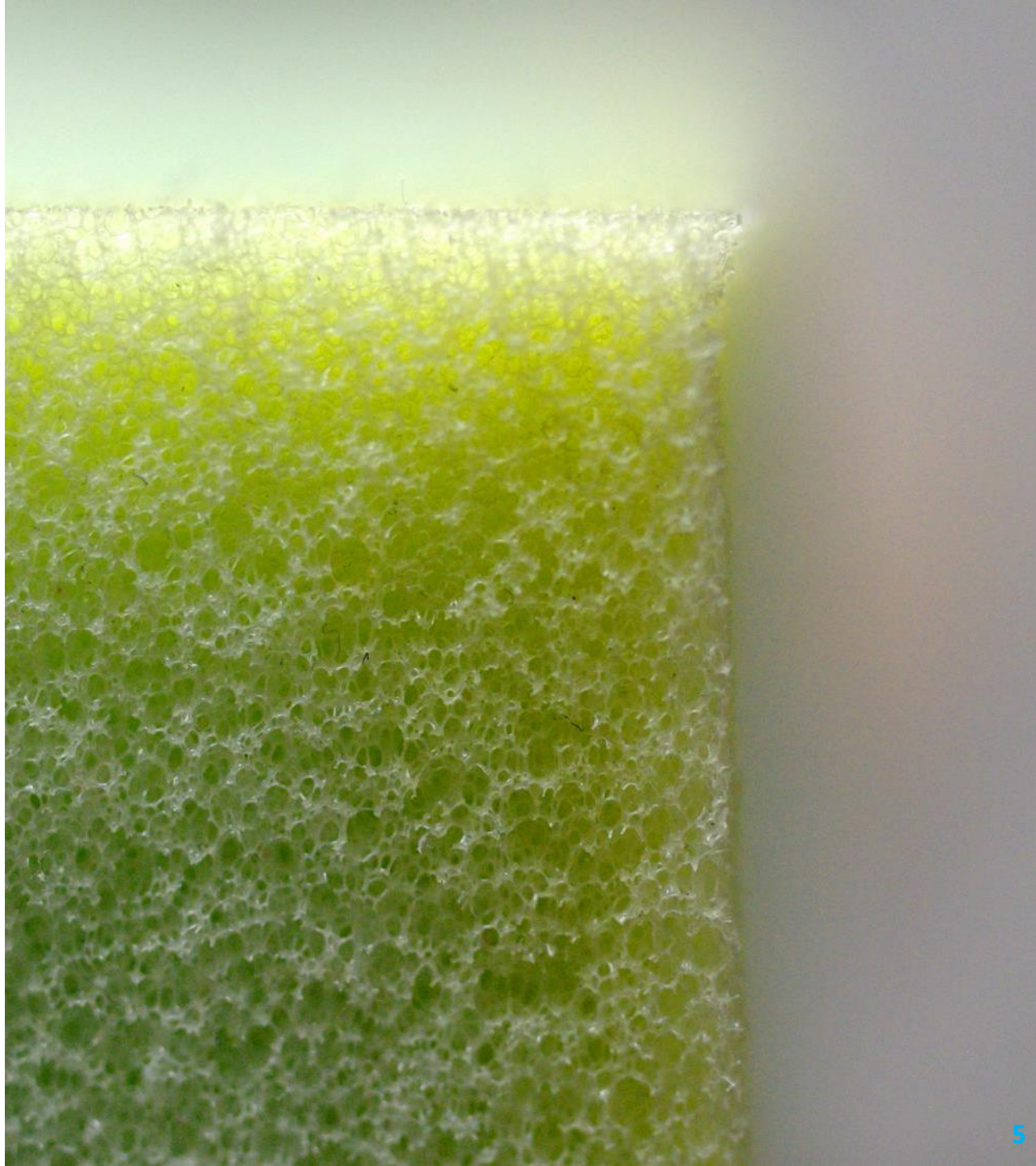





# 2

## Closed-cell foam liner

The open-cell foam has to be kept cool and dry for optimal impact performance, so we use a closed-cell foam liner to keep it that way.

Also, in a very high-energy impact (reaches max compression distance of helmet), the closed-cell foam absorbs the remaining impact energy.

# 3

## Tubular vent structures

In a rotational impact, the torsional flexibility of the open-cell foam allows for the helmet shell to rotate slightly about the skull.

The tubular vent structures are made of resilient closed-cell foam that realigns the helmet back on the user's head after slight rotations.

This prevents the helmet from pulling on the skull like today's helmets currently do with their "occipital and 360° locks".

By letting the helmet do the majority of the work, instead of the skull, the amount of potential shearing on the brain is reduced dramatically.

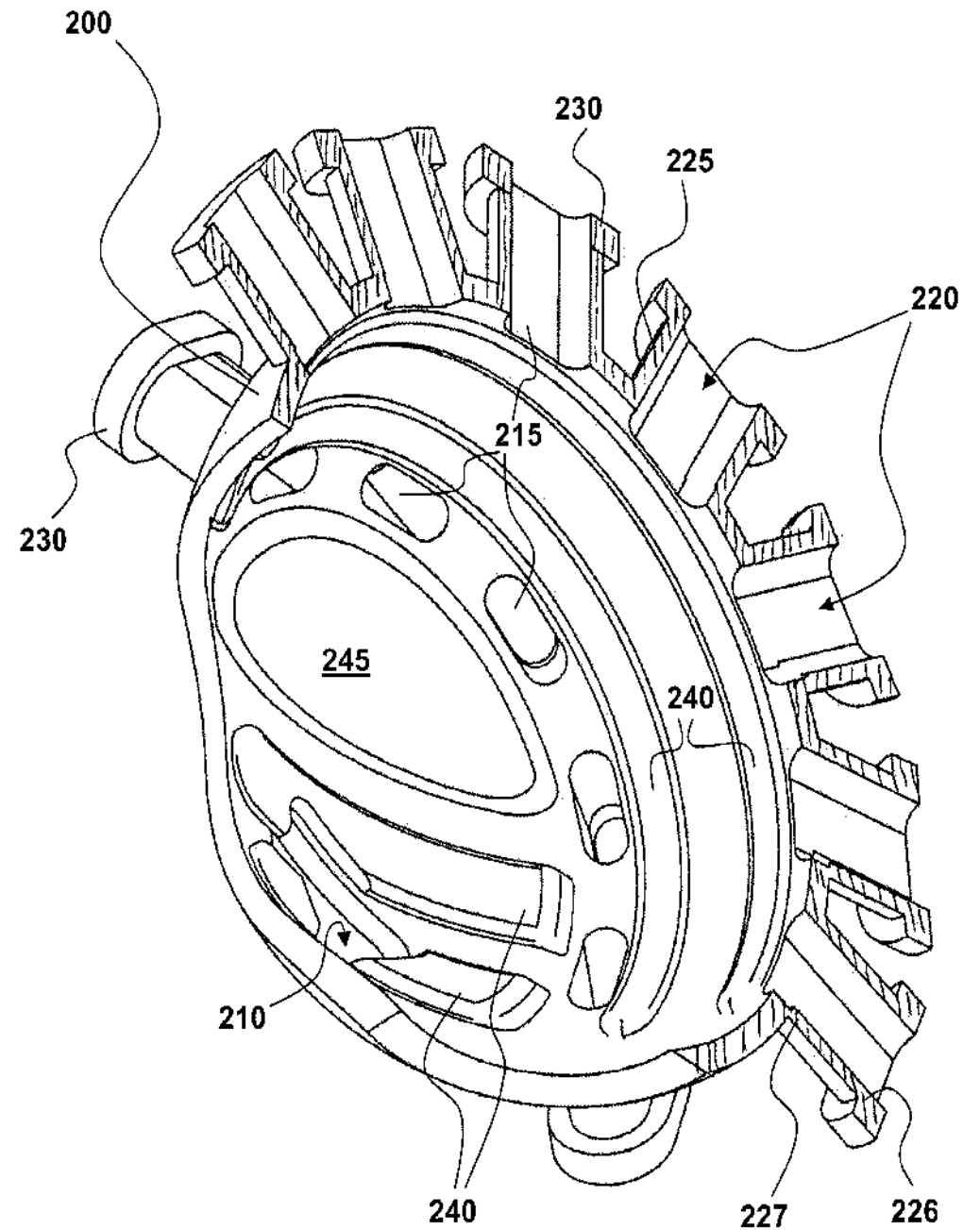

# Market Opportunity

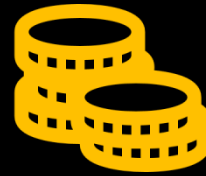

A superior technology can command the **upper end price** for a helmet range in each sport

A superior technology can steal a **larger market share quicker** for concussion epidemic sports

## For just the U.S. Market

Sports participation in millions

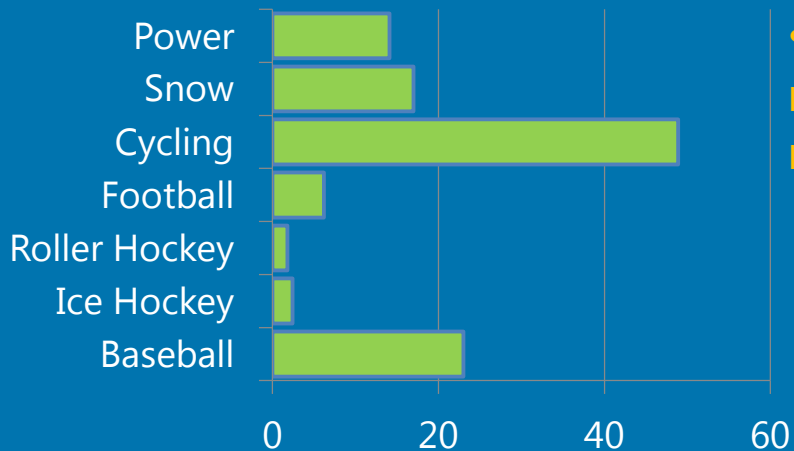

• 113 million participants  
• **\$13.4B wholesale market size in U.S. for new helmets**

## Outside the U.S.

• Ice hockey outside of the U.S. has over 1 million players in Canada. There are over 6 million ice hockey players globally in 80 countries.

• Ice hockey global wholesale market value in replacement helmets is **\$870M**

• **For all sports mentioned the global wholesale market is considerably larger but was not quantified**

### Assumptions:

- upper end of current retail prices (in \$US): baseball \$80, hockey \$290, football \$530, cycling \$160, snow sports \$350, power sports \$530
- for simplicity we set wholesale pricing at half of retail pricing which will differ for different sports and brands in real life
- market size is the total of every participant wearing a new replacement helmet for that sport, whereas there are continued sales into future years due to youth head-size growth, regulated replacement schedules, new players etc. We also ignored potential applications for professions such as military and rescue
- market participation numbers came found in 2012 10K form data from helmet companies, actual 2017 numbers projected to be higher



**EXAMPLE DATA**  
from drop test comparisons



# Major Brand Production Hockey Helmet

# Our Technology

**Severity Index = 708**



**Severity Index = 81**

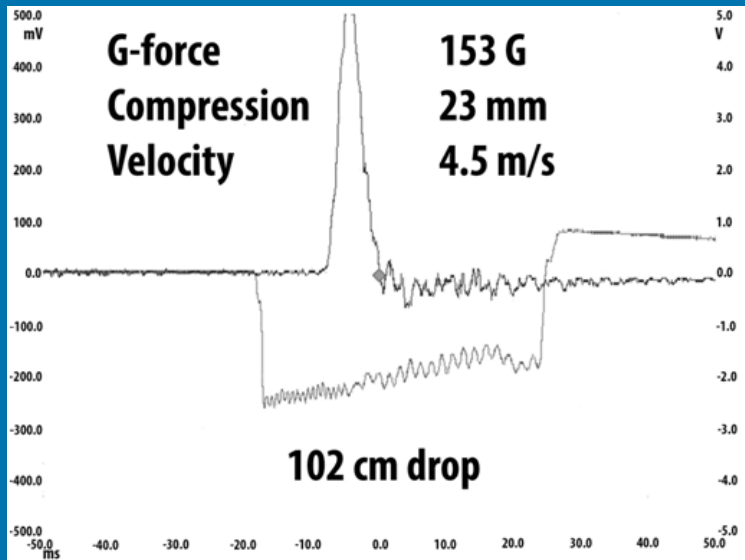

Our technology manages energy absorption more evenly and results in a dramatic reduction in the metric of SI which is a good measure of the potential for an impact to cause a concussion

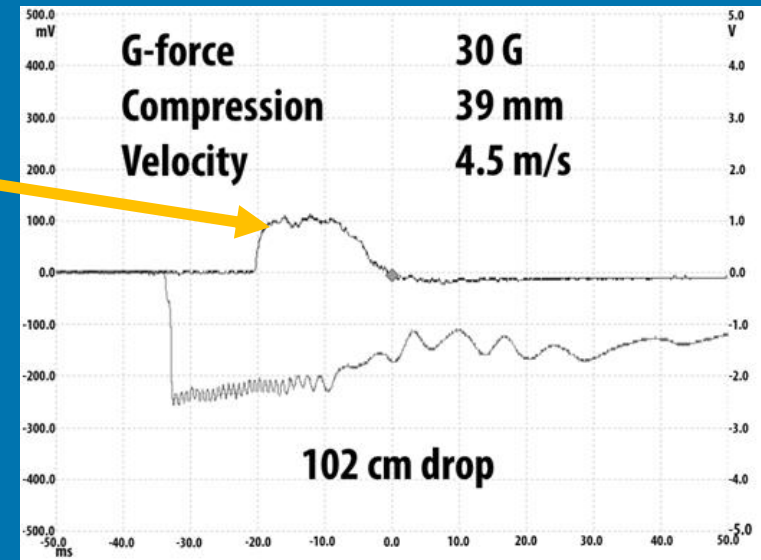

Results were tested over the range of indoor and outdoor hockey playing temperatures from 5°C to -25°C. Shown are test results at approximately the midpoint in this range.

# product

## Why can this be the next big thing? More versatile in-game energy absorption

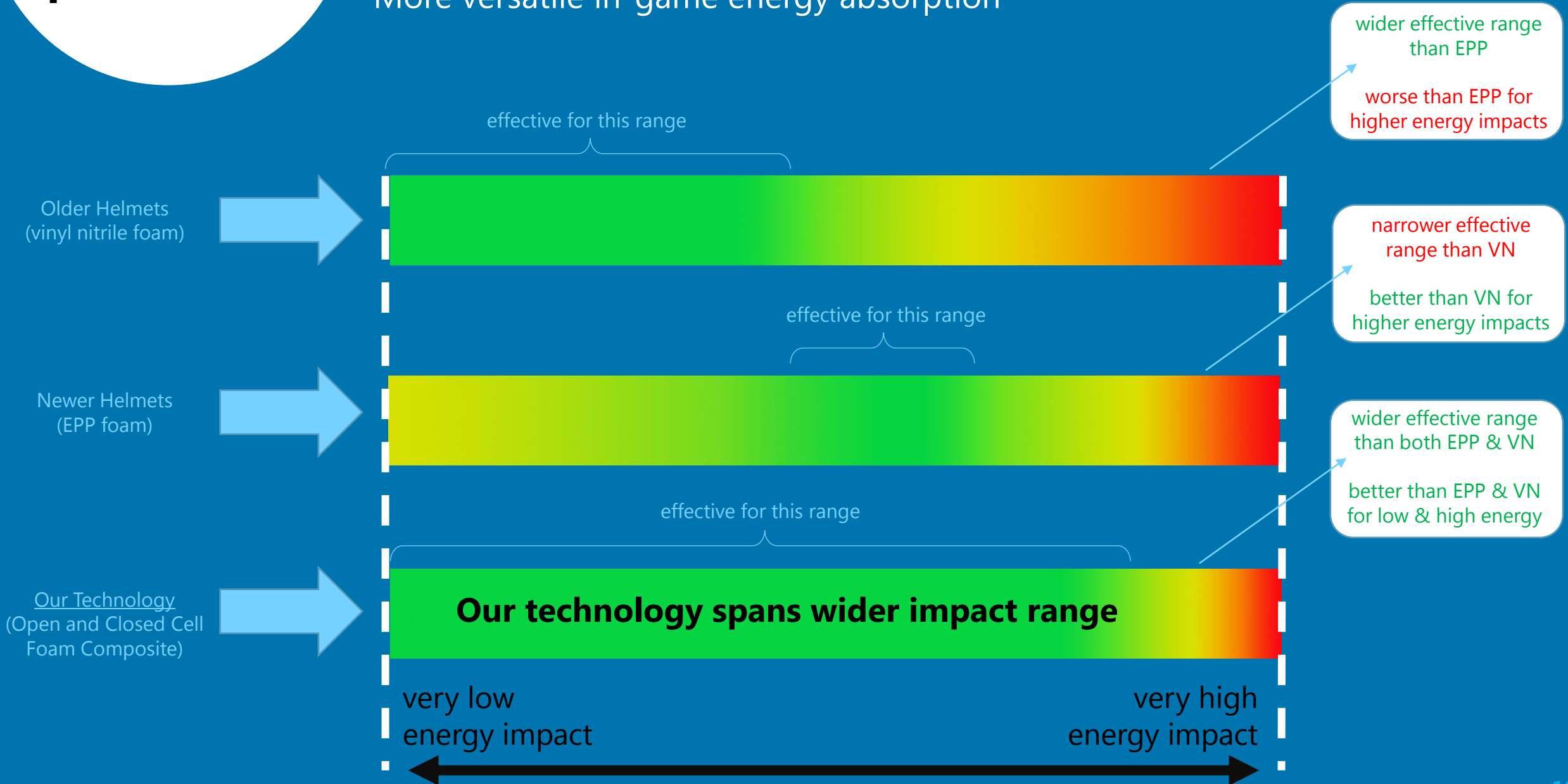

# CONTACT US – Ready to License

## What we have to offer:

- *Revolutionary new design approach with other materials*
- *Canadian & U.S. patents issued*

## What we are looking for:

- *Agents to represent us for some manufacturers*
- *Manufacturers interested in taking this to market in one or more sports*
- *Non-sports interest from manufacturers dealing with military, rescue, etc.*

**Phone: 613-369-4367**

**Email: [helmets@betterhelmets.com](mailto:helmets@betterhelmets.com)**

**For an expanded chart set, please submit a  
request using our form at [www.BetterHelmets.com](http://www.BetterHelmets.com)**

We will entertain inquiries from both agents that may want to represent us to manufacturers and directly from interested manufacturers.